

ABAQUS

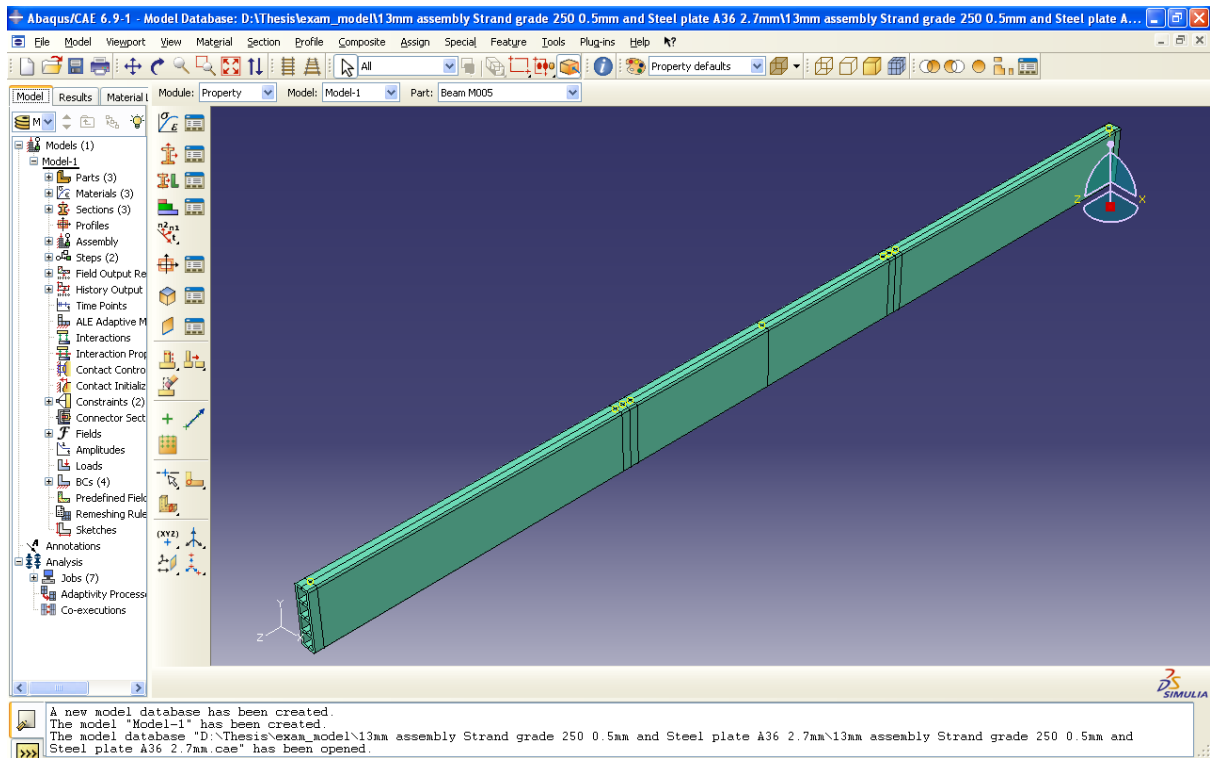

Figure 1 modeling for wood/polyvinyl chloride

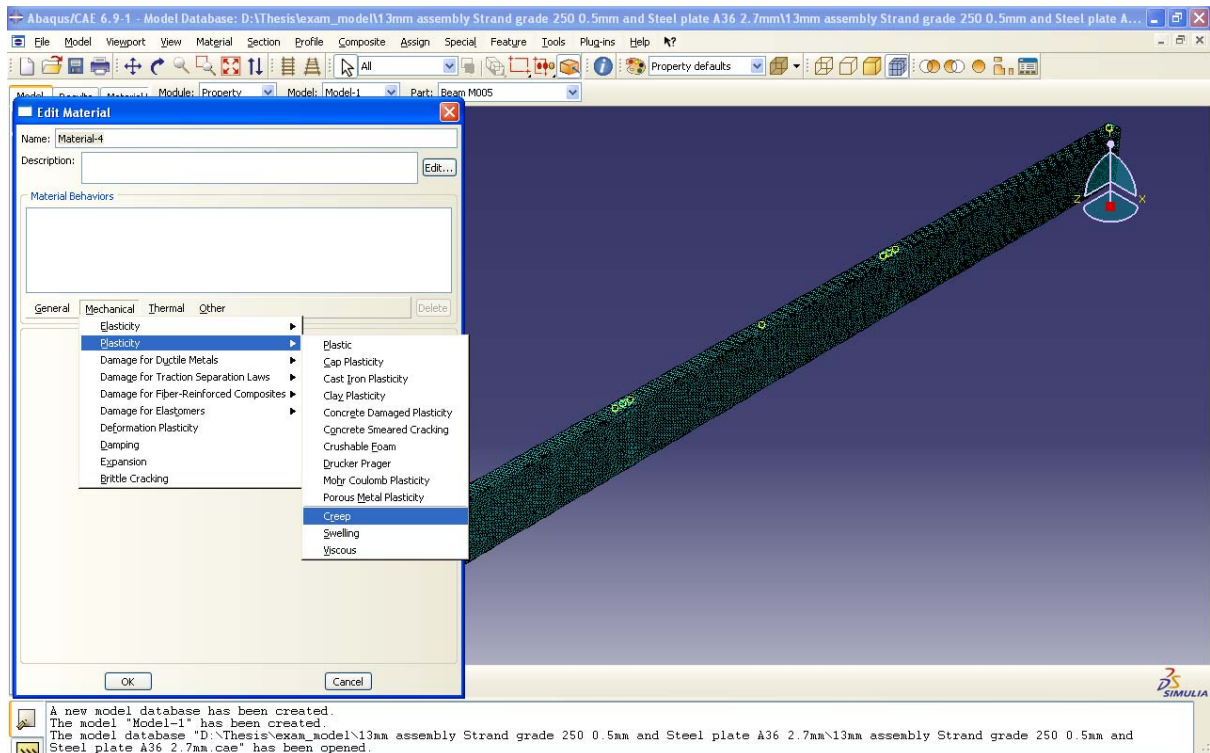

Figure 2 setting material

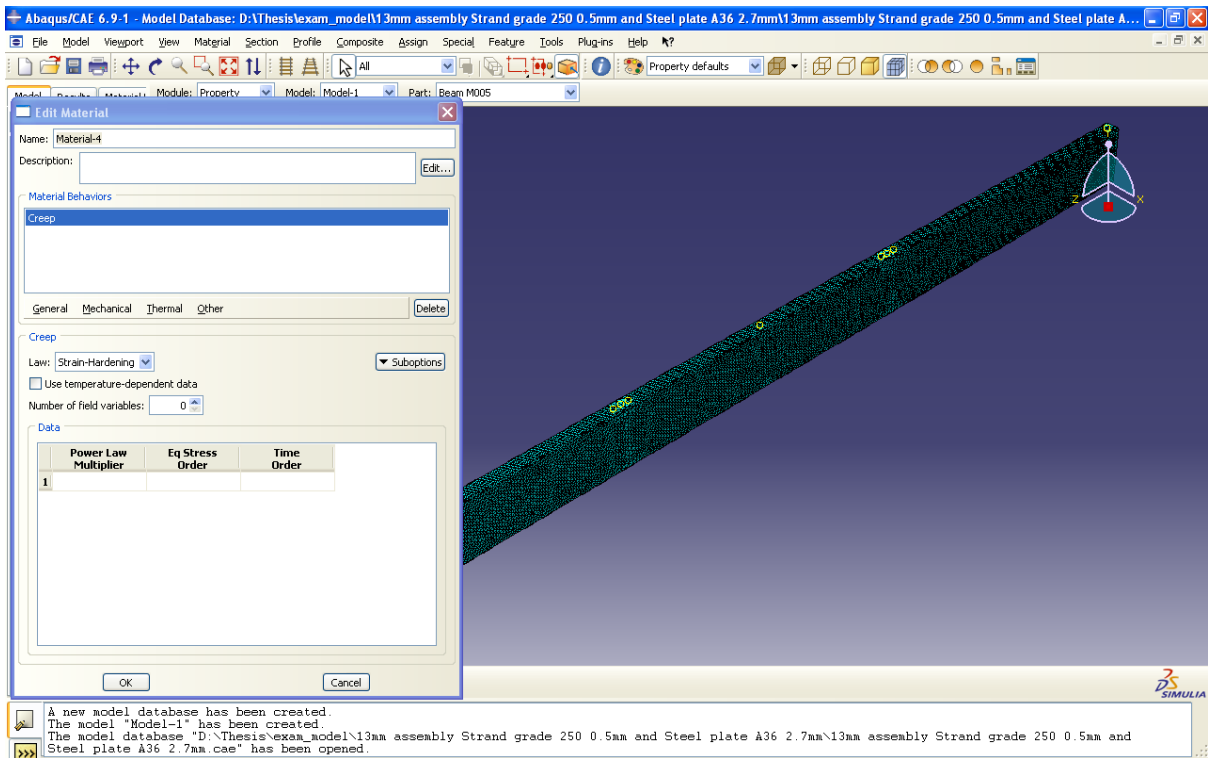

Figure 3 Mechanical specifies

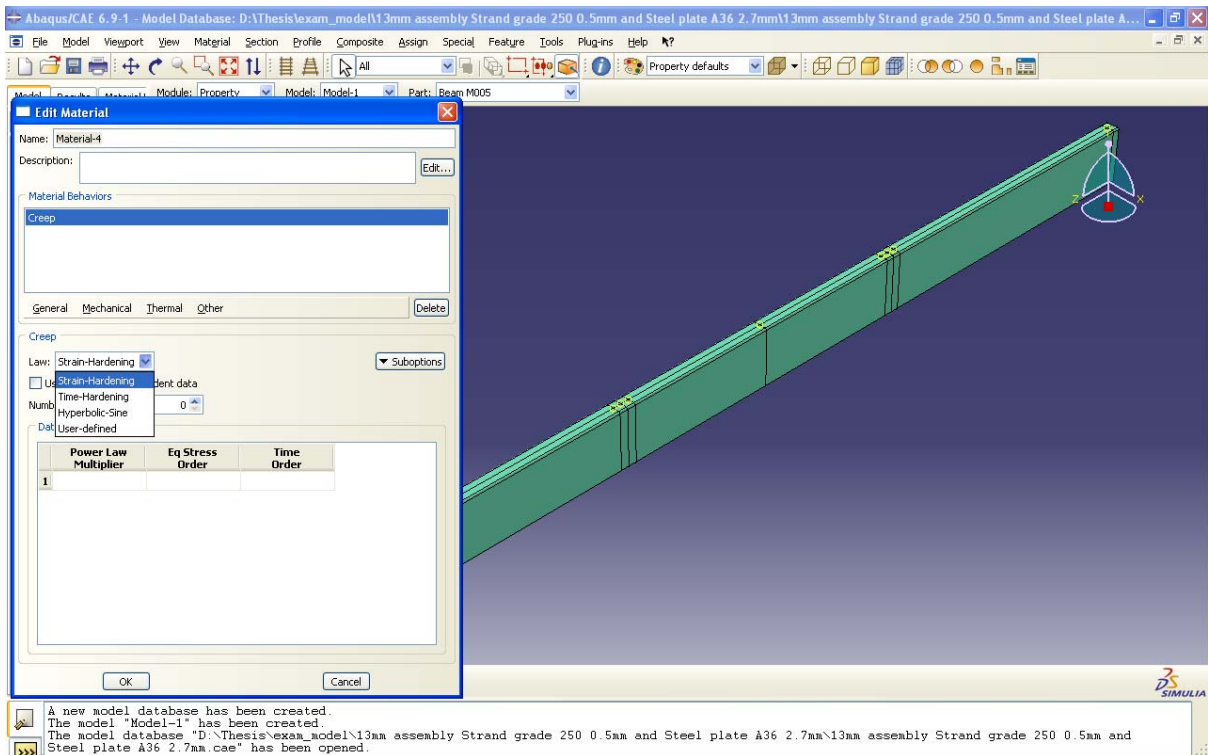

Figure 4 Creep law

- How to find the power law multiplier, eq stress, time order ?